

NOTES:

 MATERIAL: STEEL
 CHAMFERS: MACHINIST'S DISCRETION

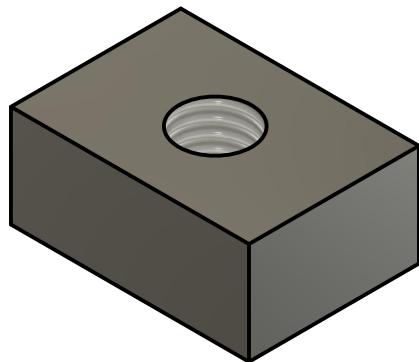

UNLESS OTHERWISE SPECIFIED
 DIMENSIONS ARE IN INCHES
 TOLERANCES:
 ANGULAR $\pm 0.5^\circ$
 FRACTIONAL $\pm 1/32$
 X.X ± 0.015
 X.XX ± 0.010
 X.XXX ± 0.005
 X.XXXX ± 0.0005

PROJECT

8x14 Change Gears

TITLE

Stud Position Nut

APPROVED	SIZE	CODE	DWG NO	REV
CHECKED	A			A
DRAWN Daniel Sherman 10/27/2016	SCALE 2:1	WEIGHT	SHEET 1 of 1	