

SECTION B-B

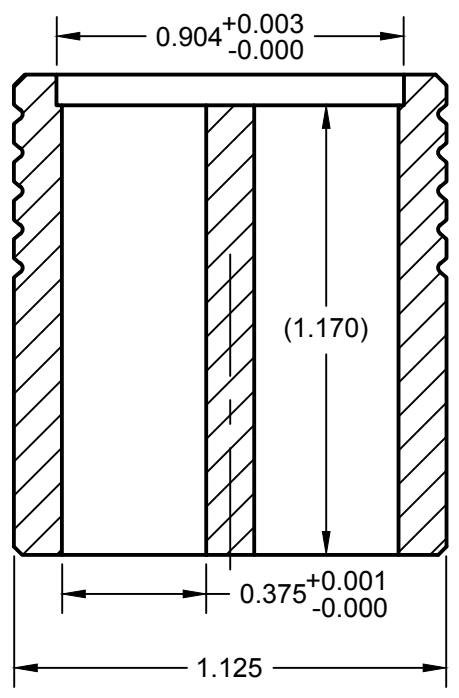
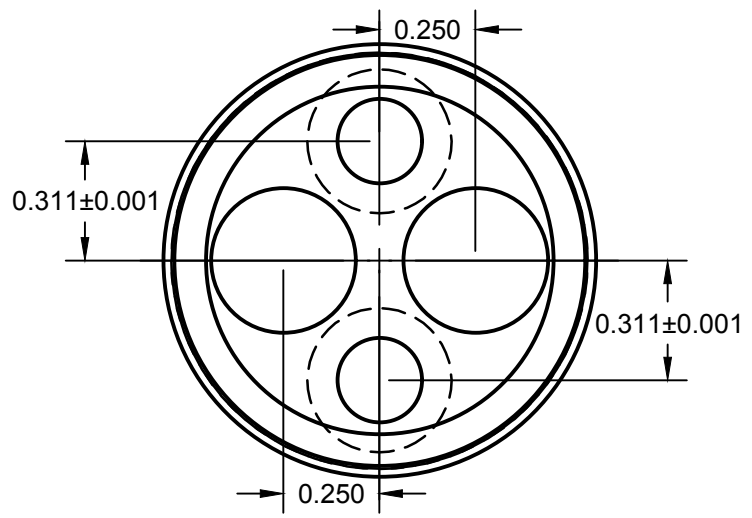
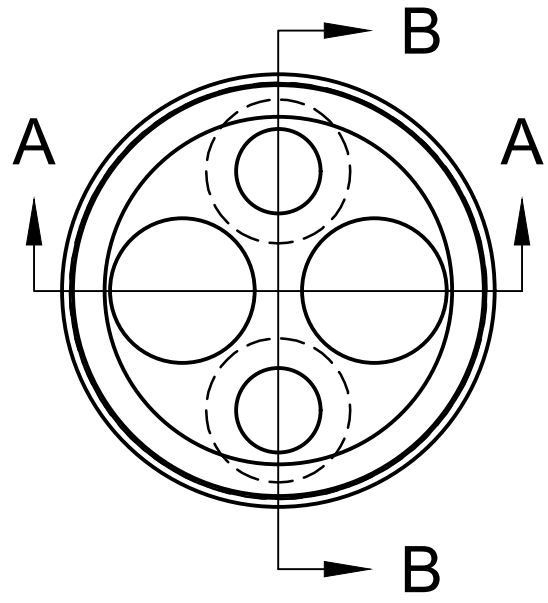

SECTION A-A

NOTES:

MATERIAL: 6061-T6 ALUMINUM
 SURFACE FINISH: MACHINIST'S DISCRETION

UNLESS OTHERWISE SPECIFIED DIMENSIONS ARE IN INCHES TOLERANCES: ANGLUAR ± 0.5° FRACTIONAL ± 1/32 X.X ± 0.015 X.XX ± 0.010 X.XXX ± 0.005 X.XXXX ± 0.0005	PROJECT			
	MAGNETIC BASE TASK LIGHT			
	TITLE			
APPROVED	SIZE	CODE	DWG NO	REV
CHECKED	A			D
DRAWN Dan Sherman 12/19/2015	SCALE 2:1	WEIGHT	SHEET 1 of 2	